

# ***KaiVac<sup>®</sup> 2100 Series***

## **Operator and Parts Manual**

---

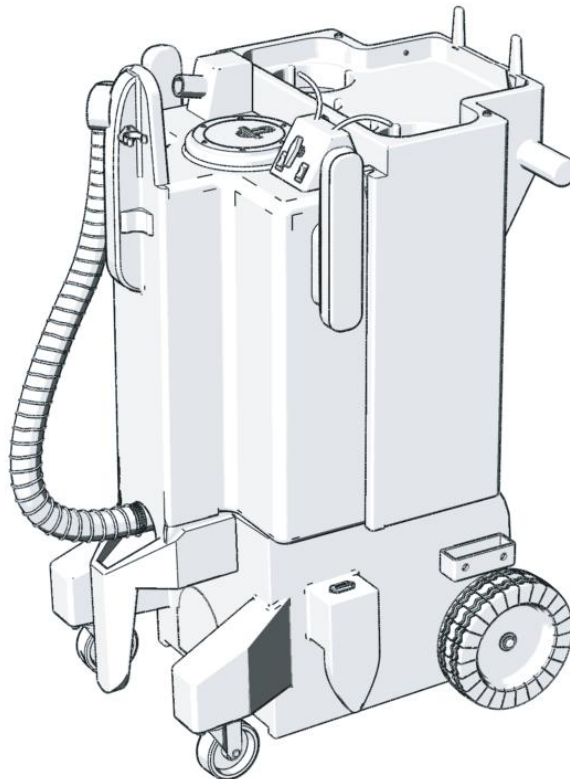

# Read First

---

<b>INSTALL DATE</b>
Please fill out card for future records
Install date _____
Serial No. _____

Read this manual prior to operation. This machine will operate at its optimal efficiency if:

- The machine is operated as described in this manual.
- The machine is maintained properly and regularly-per maintenance instructions.
- The machine is maintained with manufacturer parts only.

Carefully unpack and inspect your new KaiVac cleaning machine for shipping damage. Each unit is tested and thoroughly inspected before shipping. For instructions regarding shipping damage, contact Kaivac, Inc. immediately. All returns must have a Return Authorization Number (RAN), which is available by calling the Kaivac, Inc. Customer Service Department. Remember to protect your investment by registering your Warranty online at [www.kaivac.com](http://www.kaivac.com) or mailing/faxing in the form on page ii.

---

## TABLE OF CONTENTS

---

### Getting Started

Limited Warranty Protection Plan.....	i
Warranty Registration Form.....	ii
Introduction.....	1
Safety Precautions.....	2-3

### Operating your KaiVac

Preparing your KaiVac for use.....	5
Operating your KaiVac using the S-I-M-P-L-E Process.....	6

### Maintaining your KaiVac

Machine Maintenance.....	7
Vac Tank Cleanout Instructions.....	8
Hepa filter replacement Instructions.....	9
Troubleshooting.....	10-12
Machine Diagrams.....	13-19
Parts Listings.....	20-22

# Limited Warranty Protection Plan

---

The KaiVac has been engineered and tested to provide long lasting performance. This warranty covers defects in workmanship or materials under normal use and service from the date of purchase.

Kaivac, Inc. warrants the following components to be free from defects in materials and workmanship for these time periods:

- 1.) Extended Warranty for end users who use only Kaivac chemicals for the life of the machine.
  - 5 years on rotationally molded parts
  - 3 years on other parts (excluding wear items)
  - 1 year on labor
- 2.) Standard Warranty (for approved non-Kaivac chemicals)
  - 1 year parts and labor
- 3.) Chemicals that have not been approved by Kaivac. (If uncertain, please call Kaivac to check.)
  - No warranty

All KaiVac replacement parts are guaranteed for 90 days from the date of installation. Normal wear items such as wheels, hoses, seals, gaskets, cords, casters, squeegees and GFCI are excluded from warranty coverage.

All warranty claims must be accompanied by a Return Authorization Number (RAN), which is available by calling the Kaivac, Inc. Customer Service Department. No returns will be accepted without a RAN.

This warranty does not apply to return freight costs, damage or defect caused by accident, negligence, misuse, fire or repair done by anyone other than a Kaivac authorized repair center. In no event shall Kaivac, Inc. be liable for incidental or consequential damages, or any damages to persons or property.

Please Note: Under no circumstances will the seller be liable for any loss, damage, expenses or consequential damages arising in connection with the use or inability to use seller's product. Kaivac, Inc. reserves the right to make changes or improvements to its equipment without notice. Some states do not allow the exclusion or limitation of incidental or consequential damages. This warranty is in lieu of any other warranty expressed or implied, including any warranty of merchantability or fitness for a particular purpose.

# Warranty Registration Form

To be completed and mailed or faxed by the customer purchasing equipment.  
Return this warranty card within ten days of purchase.

Purchased By:

Name \_\_\_\_\_ Title \_\_\_\_\_

Company \_\_\_\_\_

Street Address \_\_\_\_\_

City \_\_\_\_\_ State \_\_\_\_\_ Zip Code \_\_\_\_\_

Phone Number \_\_\_\_\_ Fax \_\_\_\_\_

Date Purchased \_\_\_\_/\_\_\_\_/\_\_\_\_ Name of Distributor \_\_\_\_\_

I would like to receive updated information Yes\_\_\_\_ No\_\_\_\_

Email address: \_\_\_\_\_

KaiVac® 1550 (KaiZen™)       KaiVac® 1750       KaiVac® 1220

KaiVac® 1720       KaiVac® 2150       KaiVac® 1250

Serial Number \_\_\_\_\_

## Type of Business

- |   |                                      |
|---|--------------------------------------|
| <input type="checkbox"/> School/University    | <input type="checkbox"/> Industrial  |
| <input type="checkbox"/> Hospital/Health Care | <input type="checkbox"/> Office      |
| <input type="checkbox"/> Contract Cleaner     | <input type="checkbox"/> Other _____ |

## Intended Uses (check all that apply):

- |  |  |   |
|--|--|---|
| <input type="checkbox"/> Restroom Cleaning | <input type="checkbox"/> Cleaning Around Machinery | <input type="checkbox"/> Classroom Cleaning |
| <input type="checkbox"/> Floor Stripping   | <input type="checkbox"/> Stairwell Cleaning        | <input type="checkbox"/> Other _____        |
| <input type="checkbox"/> Kitchen Cleaning  | <input type="checkbox"/> Locker and Shower Room    |   |
| <input type="checkbox"/> Carpet Extraction | <input type="checkbox"/> Hallway Cleaning          |   |

Thank you for registering for our warranty program. As our way of saying thanks, we'd like to send you a free microfiber KaiTowel.™

Please return completed forms to:

Kaivac, Inc.  
401 S. Third Street  
Hamilton, OH 45011

Or Fax to: (513) 887-4601

# Introduction

---

## Inspection

Carefully unpack and inspect your new KaiVac cleaning machine for shipping damage. Each unit is tested and thoroughly inspected before shipping. For instructions regarding any shipping damage, contact Kaivac, Inc. immediately. All returns must have a Return Authorization Number (RAN), which is available by calling the Kaivac, Inc. Customer Service Department.

## Warnings

DO NOT operate with a frayed, worn or damaged electrical cord.

DO NOT use to pick up flammable or combustible materials.

DO NOT run the pump without water in the water tank.

DO NOT use hot water.

DO NOT remove the float shutoff.

ALWAYS test chemicals for compatibility on surfaces to be cleaned.

ALWAYS winterize your Kaivac equipment between uses if it will be exposed to freezing temperatures.

## Grounding Instructions

THE KAI VAC MUST BE GROUNDED. If it should malfunction or stop working, grounding provides a path of least resistance for the electrical current and reduces the risk of electrical shock. The KaiVac is equipped with a ground fault circuit interrupter (GFCI) to further reduce danger of electric shock. It must be maintained and tested regularly. An equipment grounding cord and plug is included with the unit. The plug must be inserted in an appropriate outlet that has been properly installed and grounded in accordance with all local codes and ordinances. Cutting off the ground wire or using a cord with an ungrounded plug will void the warranty on the unit, and Kaivac, Inc. will NOT accept responsibility for the unit.

Improper connection of the equipment grounding cord can result in the risk of electrical shock. Ask a qualified electrician or service person to check the outlet grounding if you are unsure. Do not modify the plug provided with the KaiVac. If it will not fit the outlet, have a properly grounded outlet installed by a qualified electrician.

# Safety Precautions

---

## Equipment Warning

- Read all instructions to ensure safe operation of the KaiVac.

## Training

- Proper training is required before using the KaiVac. Contact your authorized Kaivac distributor for training information.
- Instruction placards are attached to each KaiVac and should not be removed.
- These placards show proper cleaning procedures and safety precautions.

## Equipment Use

- Use the equipment for the purposes specified by the manufacturer. Do not use the equipment for any other purpose.
- See the S-I-M-P-L-E operation section for proper use of equipment.

## Spray Gun

- Never point the spray gun at people.

## Prevention of Electrocutation

- Use the ground fault circuit interrupter (GFCI) with the KaiVac at all times.
- Test the GFCI before each use.
- Do not spray liquid from the KaiVac onto electrical outlets or on any electrical devices.

## Personal Protection

- Wear gloves, eye protection and ear protection when operating the KaiVac.

## Machine Integrity

- Do not run the pump dry. This will void the machine warranty.
- Do not run hot water through the pump. This can cause pump cavitation and will void the warranty.
- Always be sure the water tank and water line filters are clear of debris. Running the pump with clogged filters can cause pump damage.
- Replace any damaged cords before use.

## Winterize your Kaivac Equipment

- Your Kaivac machinery should be winterized between uses if it is to be exposed to freezing temperatures.
- To winterize your machine:
  - Pour 1/2 gallon of windshield wiper fluid into the empty water tank.
  - Aim the spray gun into the water tank.
  - Run the pump and spray the gun until the fluid begins running through.

## Chemical Use

- Only use chemicals approved for use with the KaiVac. Use of non-Kaivac chemicals may cause machine damage and will reduce warranty periods. Turn chemical line off when not in use.
- Keep the appropriate chemical MSDS on hand at all times.
- Cleaning chemicals should not be put in the water tank (with the exception of KaiDri in small amounts). Chemicals in the water tank can harm operator and machine because:
  - Chemicals in the water tank must pass through the pump, which may cause premature pump failure.
  - Use of chemicals in the water tank voids the warranty.
  - Chemicals in the water tank will be aerosolized and may harm the operator.

## Electrical

- Connect to a properly grounded outlet only.
- Do not pull the KaiVac by the cord or use the cord as a handle.
- Do not close a door on the cord or pull the cord around sharp edges or corners.
- Do not run over the cord.
- Keep the cord away from heated surfaces.
- Turn off the unit before unplugging.
- Do not pull on the cord to unplug. Grasp the plug at the outlet and pull.

## Prevention of Water Damage to Buildings

The KaiVac is to be used on water resistant building surfaces only. These include concrete, terrazzo, ceramic tile and quarry tile.

The KaiVac may be used for stripping on vinyl composite tile floors, but daily cleaning of resilient flooring using the KaiVac is not recommended.

Never overflow the water tank or the vacuum recovery tank.

Discontinue use if any leaks occur in the KaiVac.

**CAUTION:** Prior to cleaning, always inspect area to ensure that the surfaces to be cleaned are water- safe. In addition, check for poor construction, damaged walls and floors, missing or damaged tiles or grout, missing or insufficient caulk, and loose wall coverings. If problems are discovered, resolve them prior to cleaning in order to avoid any harm that may result from exposure to water or cleaning solution.

# Preparing your Kaivac For Use

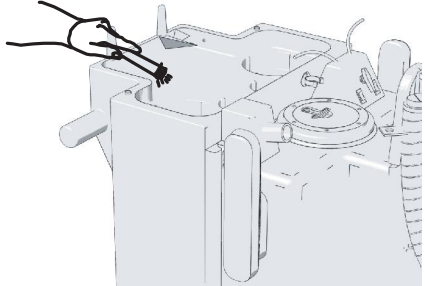
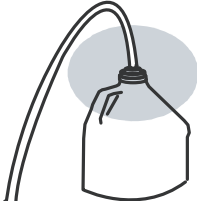
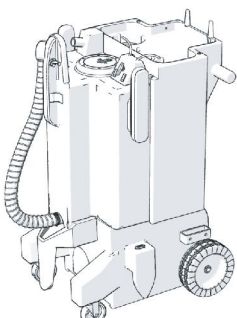
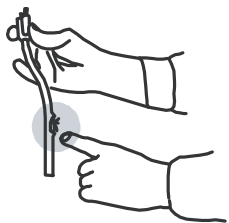
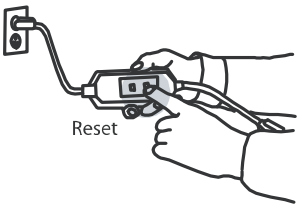
<p>1. Fill machine with clean cool water.</p>	
<p>2. Prepare the cleaning solution you will be using by attaching the chemical feed line and cap to the top of your chemical bottle and selecting the proper metering tip. (See placards for metering tip information.)</p>	
<p>3. Check machine for all tools and supplies needed to complete task.</p>	
<p>4. Check all hoses and spray lines for damage prior to use. If damage is found, do not continue until proper repairs are completed.</p>	
<p>5. Plug in machine and test GFCI (Ground Fault Circuit Interrupter) to ensure it is working properly. You are now ready.</p>	



# Operating your KaiVac using the S-I-M-P-L-E Process

## S et-up

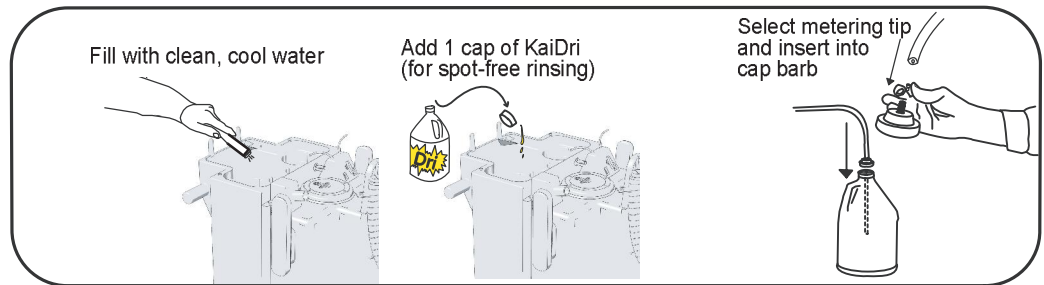

## I nject chemicals

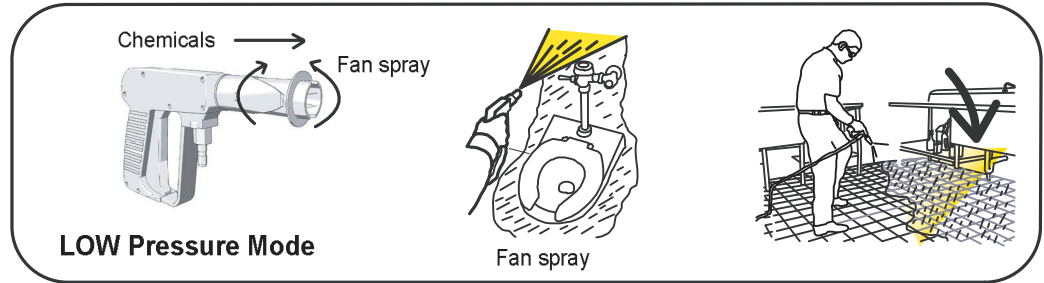

## M anual brush (optional)

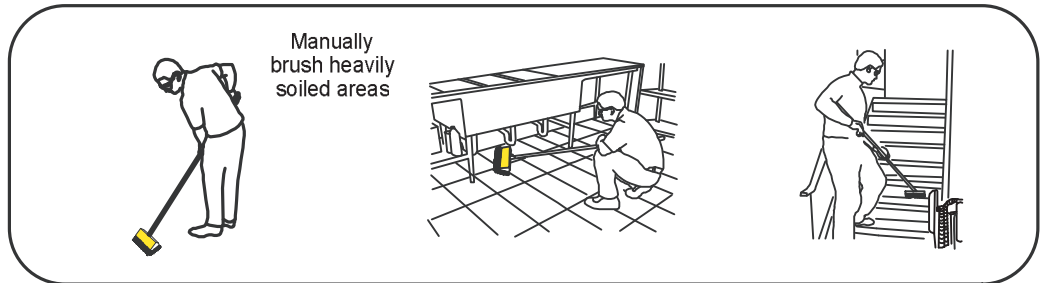

## P ressure wash and rinse

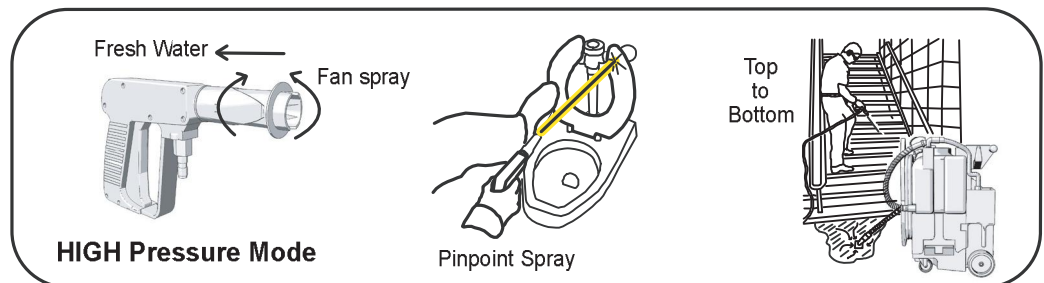

## L oop spray line

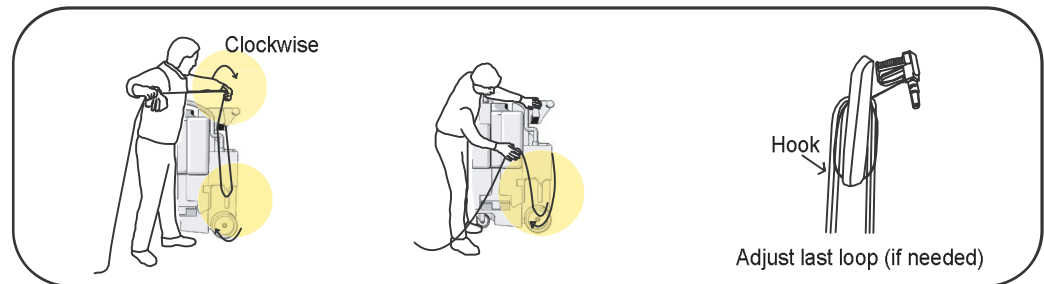

## E xtract and dry

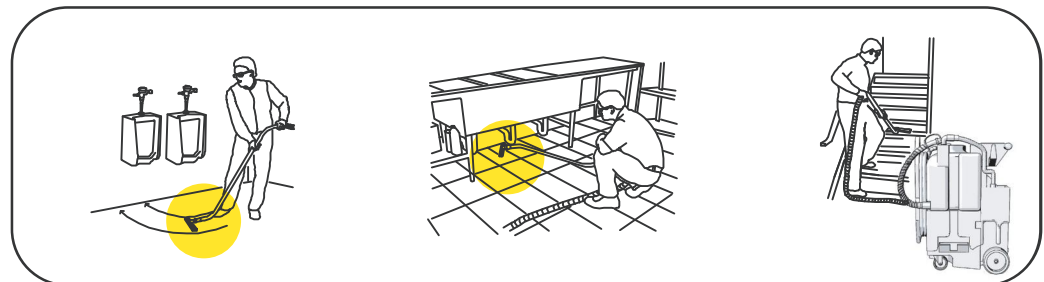

# Machine Maintenance



## CAUTION

Always make sure machine is unplugged before lifting electric cover assembly.

Item	Procedure
<b>Floor Squeegee</b>	<ul style="list-style-type: none"> <li>● Check condition of rubber squeegee blades and wheels on the floor tool.</li> <li>● Rough floor surfaces will cause the blades and wheels to wear out more quickly. Replace as necessary.</li> </ul>
<b>Spray Gun</b>	<ul style="list-style-type: none"> <li>● Check spray pattern. If spray pattern will not pinpoint, clean orifice by removing it with an Allen wrench and flushing. Replace if not pinpointing.</li> <li>● If nozzle becomes difficult to move from high to low pressure lubricate nozzle with lithium grease.</li> </ul>
<b>Pressure Hose</b>	<ul style="list-style-type: none"> <li>● Wipe clean after each use.</li> <li>● Check for cuts or frays in the hose jacket, particularly at the end of the fittings. Replace hose if cuts are found.</li> </ul>
<b>Water Tank</b>	<ul style="list-style-type: none"> <li>● Check condition of filter in water tank. Clean as needed.</li> <li>● Empty the water tank to prevent mildew and bacteria growth. Empty tank by dipping the vacuum hose onto the water tank and transferring the water to the vacuum tank.</li> </ul>
<b>Vacuum Tank</b>	<ul style="list-style-type: none"> <li>● Empty and flush vacuum tank.</li> <li>● Clean and disinfect.</li> <li>● Check the float shutoff screen to be sure it is not plugged up. A plugged filter screen restricts airflow and results in reduced suction.</li> </ul>
<b>Leaks</b>	<ul style="list-style-type: none"> <li>● Be alert for leaks around hoses, fittings, spray wand, tanks or elsewhere.</li> <li>● Discontinue use until leaks are repaired.</li> </ul>
<b>Electrical System</b>	<ul style="list-style-type: none"> <li>● The ground fault circuit interrupter (GFCI) must be tested before each use.</li> <li>● Electric cords must be inspected for tears or cuts in the insulation.</li> </ul>

# Kaivac

## Tank and Hose Cleaning

1. Unwrap vac hose and lay it on floor.
2. Suck water and air from water tank. Lower hose end to surface of water gulping both air and water. This action flushes soils from line and quickly empties water tank.

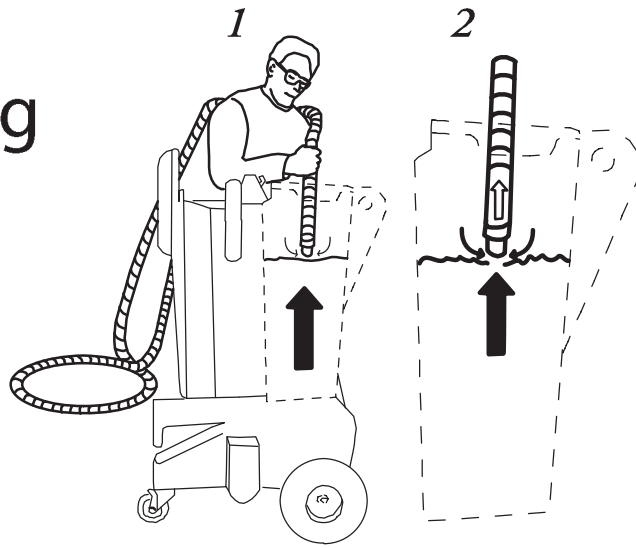

*\*Dry vac hose by connecting hose ends to vac motor, then discharge air into vac tank*

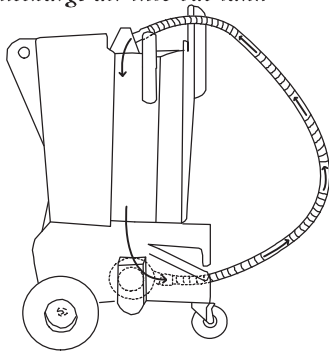

3. Vac hose can now be wrapped onto machine. Leave vac motor running while wrapping to avoid water dripping from end of hose. To completely dry hose leave vac motor running for about 3 minutes.
4. With Dump Hose opened to floor drain, spray inside of vac tank with clean water moving hose in a circular pattern to insure tank walls and float shutoff are rinsed.

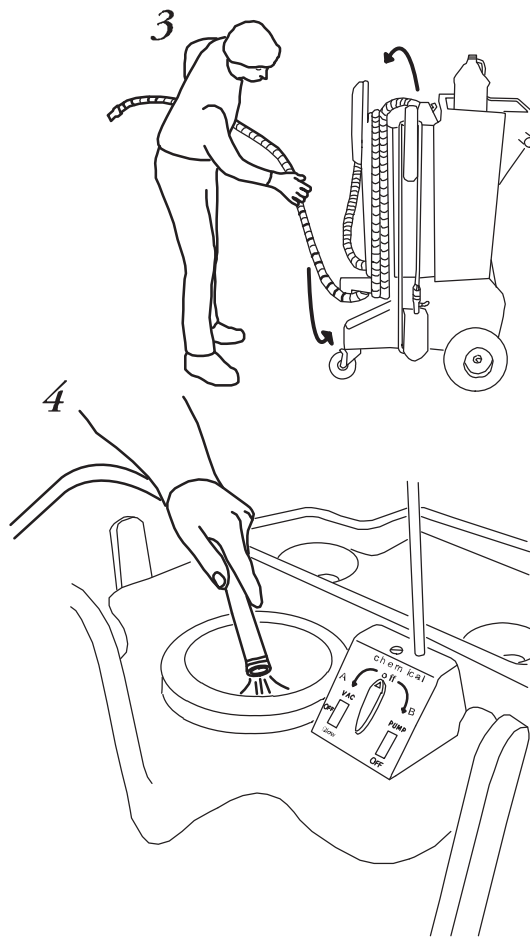

Tank and Hose Cleaning

# Hepa Filter Replacement Instructions

---

1

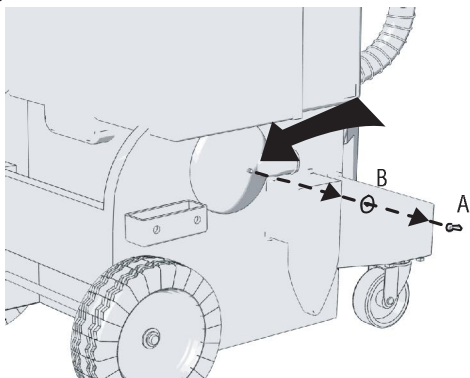

Remove wingnut (A) and washer (B) from Hepa Cover as shown above.

2

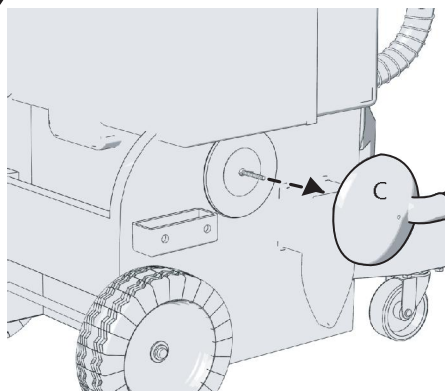

Slide Hepa (C) cover off of stud to remove.

3

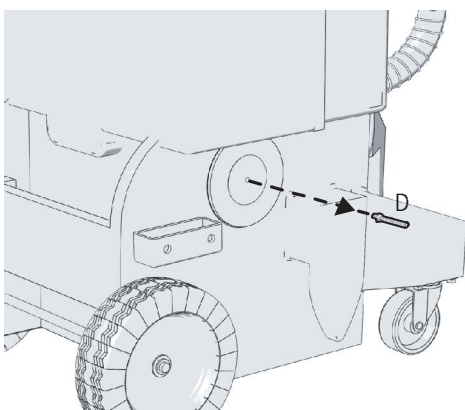

Remove threaded rod/wingnut (D) combination to free the Filter Keeper.

4

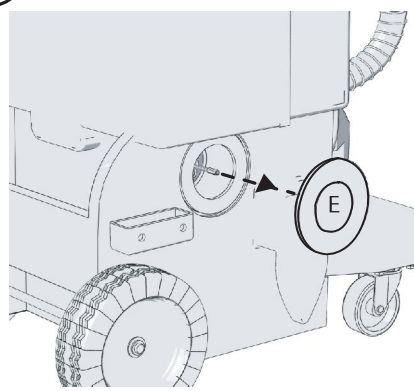

Remove the Filter Keeper (E)

5

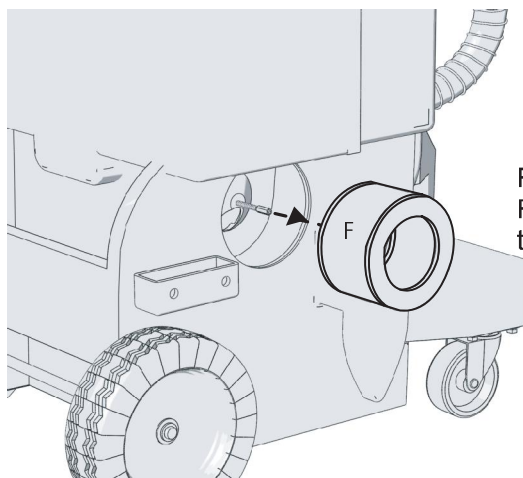

Remove Hepa filter (F) and Repeat the steps in reverse to replace.

# Troubleshooting

 **CAUTION**

Always make sure machine is unplugged before lifting electric cover assembly.

Area	Problem	Possible Cause	Solution
<b>Electrical</b>	No power to pump or vac motor.	<ol style="list-style-type: none"> <li>1. Machine not plugged in.</li> <li>2. Switch not "on."</li> <li>3. GFCI tripped.</li> <li>4. Building circuit overloaded.</li> <li>5. Switch wires loose.</li> <li>6. Connections loose.</li> </ol>	<ol style="list-style-type: none"> <li>1. Plug machine in.</li> <li>2. Check switches for "on."</li> <li>3. Test and reset GFCI.</li> <li>4. Check and reset circuit.</li> <li>5. Disconnect power and check for loose wire.</li> <li>6. Disconnect power and check for loose wire under panel.</li> </ol>
	Electrical burning smell.	<ol style="list-style-type: none"> <li>1. Vac motor brushes worn.</li> <li>2. Vac motor hung up.</li> <li>3. Pump motor hung up.</li> </ol>	<ol style="list-style-type: none"> <li>1. Remove vac motor and repair.</li> <li>2. Release pressure on hose and jog pump switch, or replace.</li> </ol>
<b>Vacuum System</b>	No/Weak vacuum.	<ol style="list-style-type: none"> <li>1. Vac tank full.</li> <li>2. Squeegee blades or wheels worn.</li> <li>3. Float shutoff screen dirty.</li> <li>4. Float ball stuck.</li> <li>5. Damaged hose.</li> <li>6. Dump hose plug missing.</li> <li>7. Access lid not tight.</li> <li>8. Vacuum hose plugged.</li> <li>9. Too much liquid in vac hose.</li> <li>10. Vac hose still wrapped.</li> <li>11. Muffler plugged.</li> <li>12. Leak in vac tank.</li> </ol>	<ol style="list-style-type: none"> <li>1. Empty vac tank.</li> <li>2. Replace wheels or blades and check periodically.</li> <li>3. Wipe off float screen to clean.</li> <li>4. Tap float and release/clean.</li> <li>5. Cut and repair/replace.</li> <li>6. Contact dealer and replace.</li> <li>7. Tighten lid hand tight.</li> <li>8. Flush hose to remove debris.</li> <li>9. Allow air in when vacuuming.</li> <li>10. Unwrap vac hose fully.</li> <li>11. Remove HEPA filter and clean.</li> <li>12. If repairable, clean and dry affected area and seal with silicone.</li> </ol>
	Moisture from exhaust.	<ol style="list-style-type: none"> <li>1. Vac tank full.</li> <li>2. Float shutoff missing.</li> <li>3. Excessive foam in vac tank.</li> </ol>	<ol style="list-style-type: none"> <li>1. Dump vac tank.</li> <li>2. Replace.</li> <li>3. Use defoamer.</li> </ol>
<b>BlowDry System</b>	No air flow.	<ol style="list-style-type: none"> <li>1. Hose disconnected.</li> </ol>	<ol style="list-style-type: none"> <li>1. Reconnect hose.</li> </ol>
	Moisture from nozzle.	<ol style="list-style-type: none"> <li>1. Water in blow hose.</li> </ol>	<ol style="list-style-type: none"> <li>1. Dry blow line.</li> </ol>
	Suction, not blow action.	<ol style="list-style-type: none"> <li>1. Vacuum hose connected to vac tank.</li> </ol>	<ol style="list-style-type: none"> <li>1. Reconnect to vac motor exhaust hose.</li> </ol>
<b>DVD System (optional)</b>	No power.	<ol style="list-style-type: none"> <li>1. Power cord not connected</li> <li>2. Power switch not on.</li> </ol>	<ol style="list-style-type: none"> <li>1. Plug cord into DVD player.</li> <li>2. Turn switch on DVD player on.</li> </ol>
	No picture.	<ol style="list-style-type: none"> <li>1. Screen is blank.</li> </ol>	<ol style="list-style-type: none"> <li>1. Close and re-open lid. Play.</li> </ol>
	No audio.	<ol style="list-style-type: none"> <li>1. No sound from player</li> </ol>	<ol style="list-style-type: none"> <li>1. Check volume control knob.</li> </ol>

# Troubleshooting



## CAUTION

Always make sure machine is unplugged before lifting electric cover assembly.

Area	Problem	Possible Cause	Solution
<b>High Pressure System</b>	No water from pump or low pressure.	<ol style="list-style-type: none"> <li>1. Out of water.</li> <li>2. Gun nozzle plugged.</li> <li>3. Air in pump (vapor lock).</li> <li>4. Gun orifice missing.</li> <li>5. Water tank filter plugged.</li> <li>6. In-line bowl filter plugged.</li> <li>7. Bowl filter lid loose.</li> <li>8. Pressure hose damaged.</li> <li>9. Quick disconnect leaking.</li> <li>10. Injector plugged.</li> <li>11. Pulse hose damaged.</li> <li>12. Regulator failed.</li> <li>13. Hose kinked.</li> <li>14. Seals in pump need replaced.</li> </ol>	<ol style="list-style-type: none"> <li>1. Fill water tank.</li> <li>2. Remove orifice with Allen wrench and clean.</li> <li>3. Use power prime technique.</li> <li>4. Replace orifice.</li> <li>5. Clean tank and filter.</li> <li>6. Remove filter cover and clean.</li> <li>7. Gently tighten bowl cover.</li> <li>8. Repair or replace.</li> <li>9. Tighten or replace.</li> <li>10. Remove safety cap from chemical and blow small amounts of compressed air into line.</li> <li>11. Repair or replace.</li> <li>12. Replace.</li> <li>13. Unkink and check for damage</li> <li>14. Remove and replace seals.</li> </ol>
	Bad fan pattern or pinpoint pattern on gun.	<ol style="list-style-type: none"> <li>1. Debris in nozzle.</li> <li>2. Orifice damaged.</li> </ol>	<ol style="list-style-type: none"> <li>1. Remove orifice with Allen wrench and clean.</li> <li>2. Remove and replace.</li> </ol>
<b>Chemical Injection System</b>	No chemical flow.	<ol style="list-style-type: none"> <li>1. Out of chemical.</li> <li>2. Safety cap not secure.</li> <li>3. Chemical valve "off."</li> <li>4. Safety cap plugged.</li> <li>5. Spray gun in wrong mode.</li> <li>6. Metering tip plugged.</li> <li>7. Injector plugged.</li> <li>8. Air entering system.</li> <li>9. Injector installed backwards.</li> </ol>	<ol style="list-style-type: none"> <li>1. Refill chemical.</li> <li>2. Check safety cap / tighten.</li> <li>3. Check on / off valve.</li> <li>4. Replace cap.</li> <li>5. Make sure gun nozzle is pulled out away from gun chemical mode.</li> <li>6. Check metering tip for clog.</li> <li>7. Remove safety cap from chemical and blow small amounts of compressed air into line.</li> <li>8. Check for air entering system around chemical lines or injector.</li> <li>9. If fluttering or pulsing sound can be heard while spraying or when machine is running it is possible that your injector is in backwards. Remove and reinstall.</li> </ol>

# Troubleshooting

 **CAUTION**

Always make sure machine is unplugged before lifting electric cover assembly.

Area	Problem	Possible Cause	Solution
<b>Chemical Injection System Con't.</b>	Not enough chemical flow.	1. Metering tip plugged. 2. Wrong metering tip.	1. Remove and clean. 2. Check and replace per chart.
	Chemical line blows off safety cap.	1. Debris in injector.	1. Remove safety cap from chemical and blow small amounts of compressed air into line.
	Water backflows into chemical bottle.	1. Bad seat on injector check valve. 2. Bad safety cap.	1. Check injector o-ring or replace. 2. Replace safety cap.
<b>Dump System</b>	Dump hose will not empty tank.	1. Dump hose plug not removed. 2. Clog in bottom of tank.	1. Remove plug. 2. Tip dump contents, remove debris.
	Dump hose leaks.	1. Hose cut. 2. Clamp loose. 3. Dump plug bushing missing. 4. Plug missing.	1. If leak is less than 4" from tank side, cut and reattach, or replace. 2. Tighten hose clamp. 3. Replace bushing. 4. Replace plug.
<b>Wheels and Casters</b>	Wheels won't roll, or they rub.	1. Flat tires. 2. Debris wrapped around axle. 3. Bearings tight. 4. Wheels too loose on axle. 5. Bearings falling out.	1. Inflate tires to 30 p.s.i. 2. Check for debris on axle. 3. Grease bearings. 4. Remove wheel, add washers to take up slack. 5. Replace bearing assembly.
<b>Squeegee Head</b>	Floor streaks.	1. Worn blades or wheels.	1. Replace wheels and / or blades.
	Squeegee head doesn't easily rotate when installed on wand.	1. Brass ring on wand not in groove. 2. Coupling nut too tight.	1. Loosen coupling nut and reposition head on groove. 2. Loosen 1/2 turn.
	Head won't stay on wand.	1. Coupling nut cracked. 2. Brass ring worn.	1. Replace. 2. Replace.
	Premature blade wear.	1. Squeegee wheels worn.	1. Check wheels for wear / replace.
	Sucks to the floor too tightly.	1. Squeegee wheels worn.	1. Check wheels for wear / replace.

# Kaivac Tool Arrangement

**Front Right View**

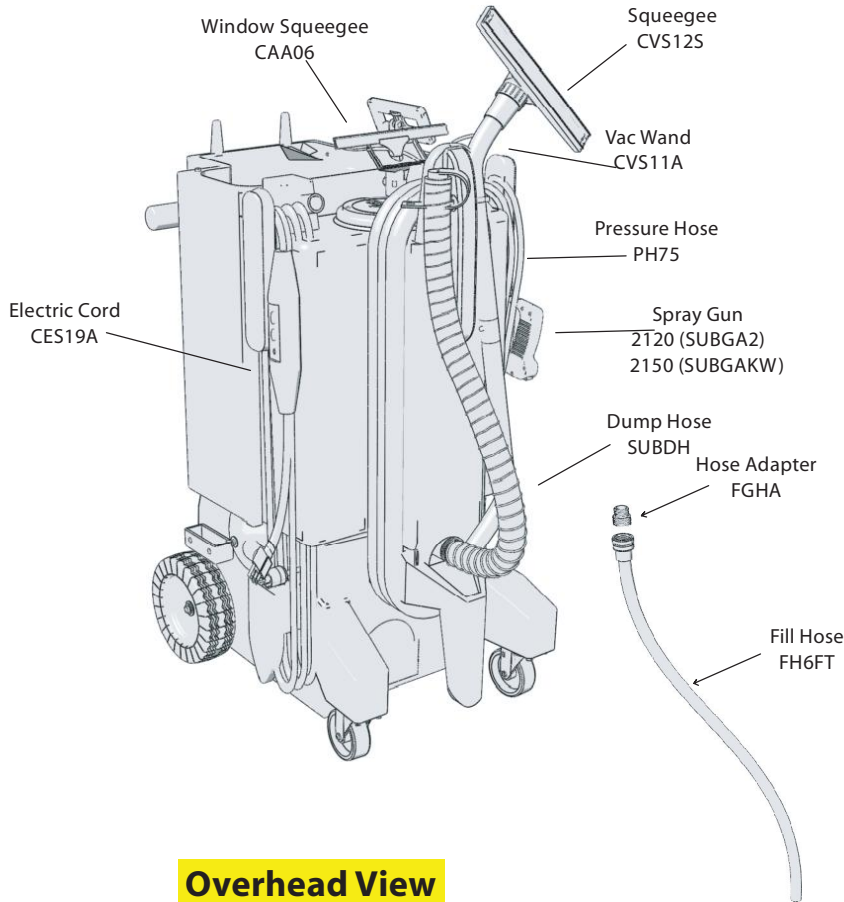

**Rear Right View**

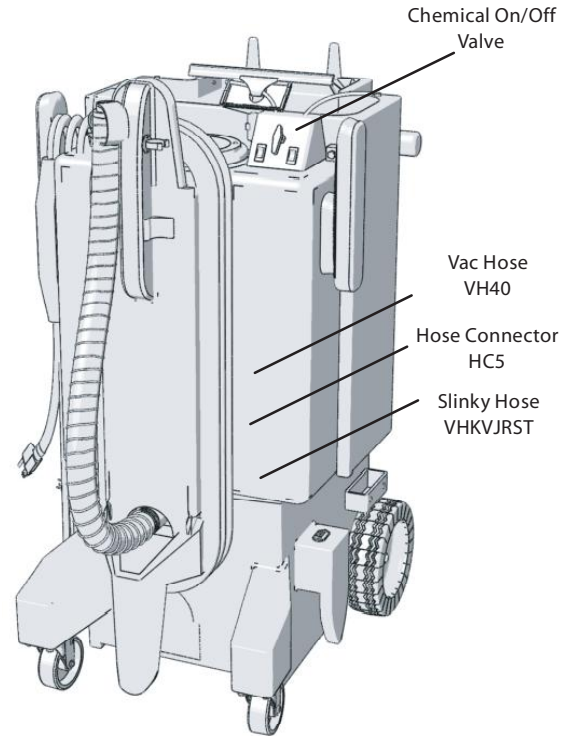

**Overhead View**

**Front**

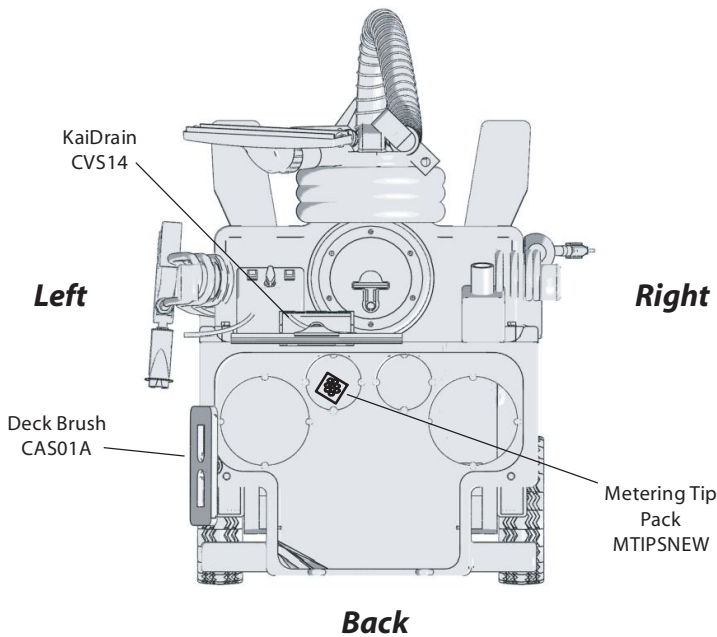

**Bottom View**

**Front**

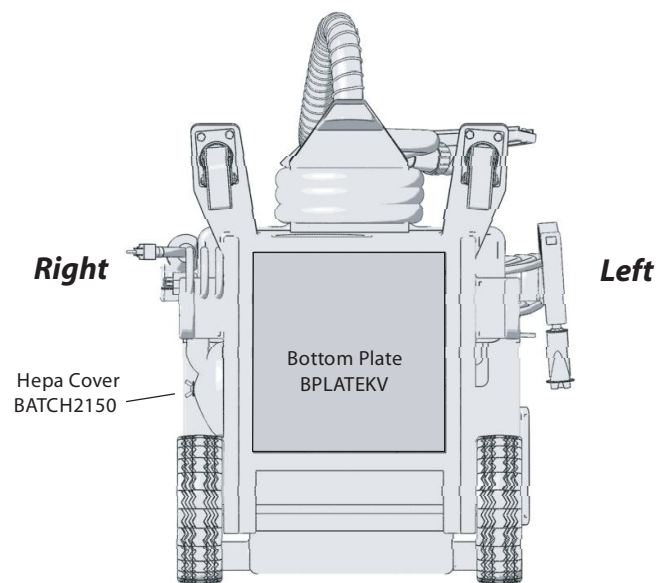



# Wiring Diagram Kaivac 2100 series

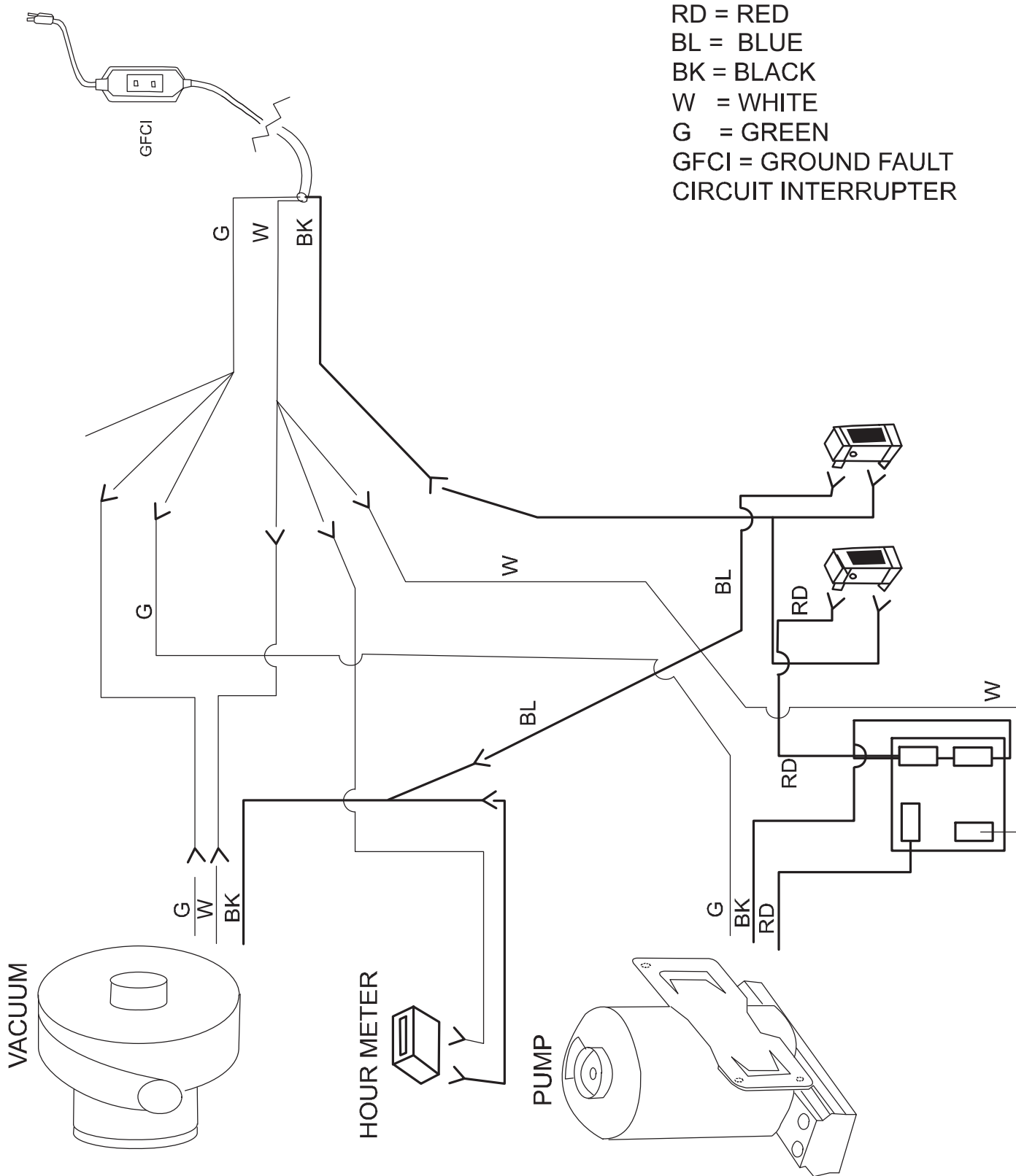

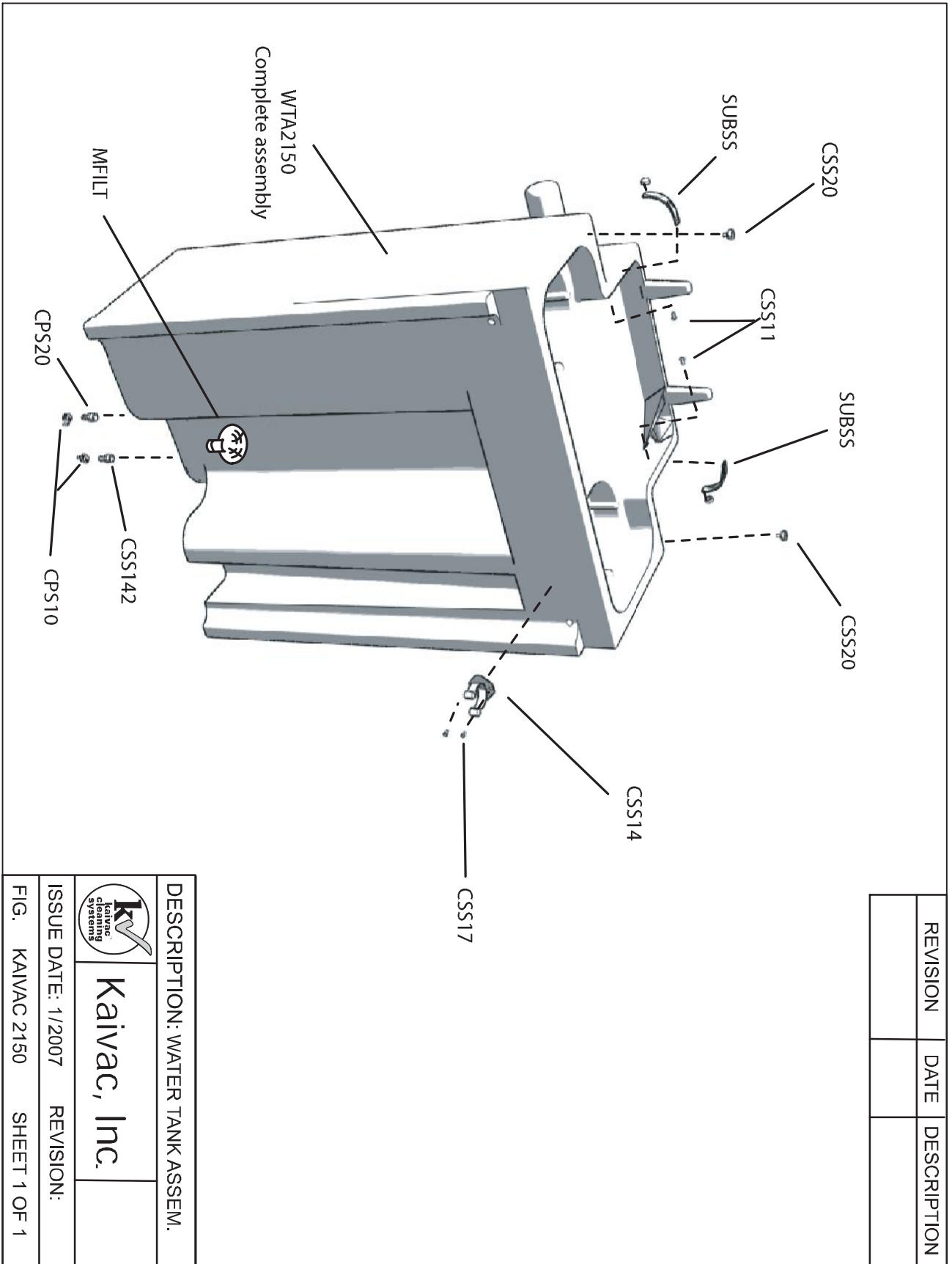



REVISION	DATE	DESCRIPTION

DESCRIPTION: WATER TANK ASSEM.	
 <b>Kaivac, Inc.</b>	
ISSUE DATE: 1/2007	REVISION:
FIG. KAIVAC 2150	SHEET 1 OF 1

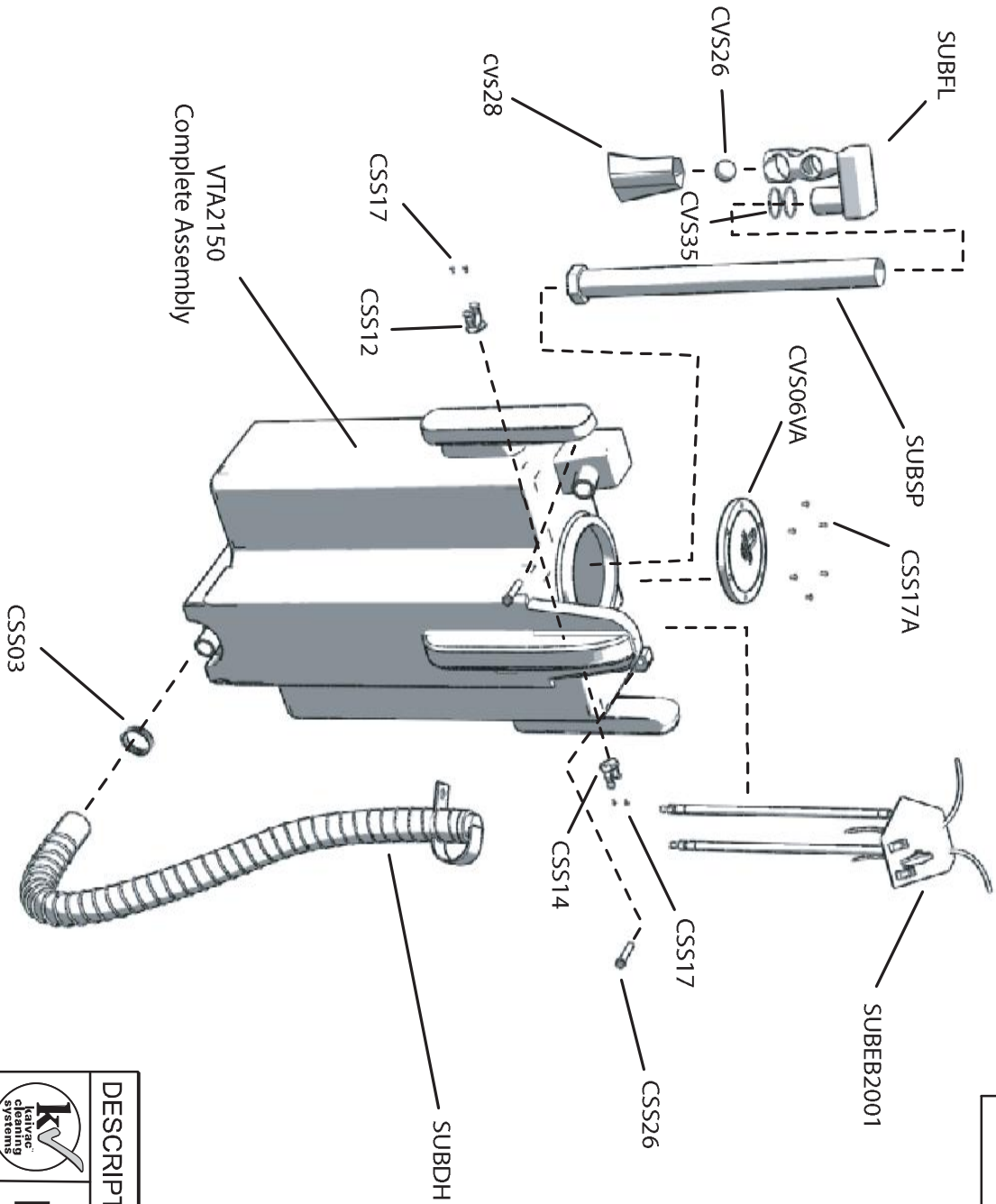
REVISION	DATE	DESCRIPTION



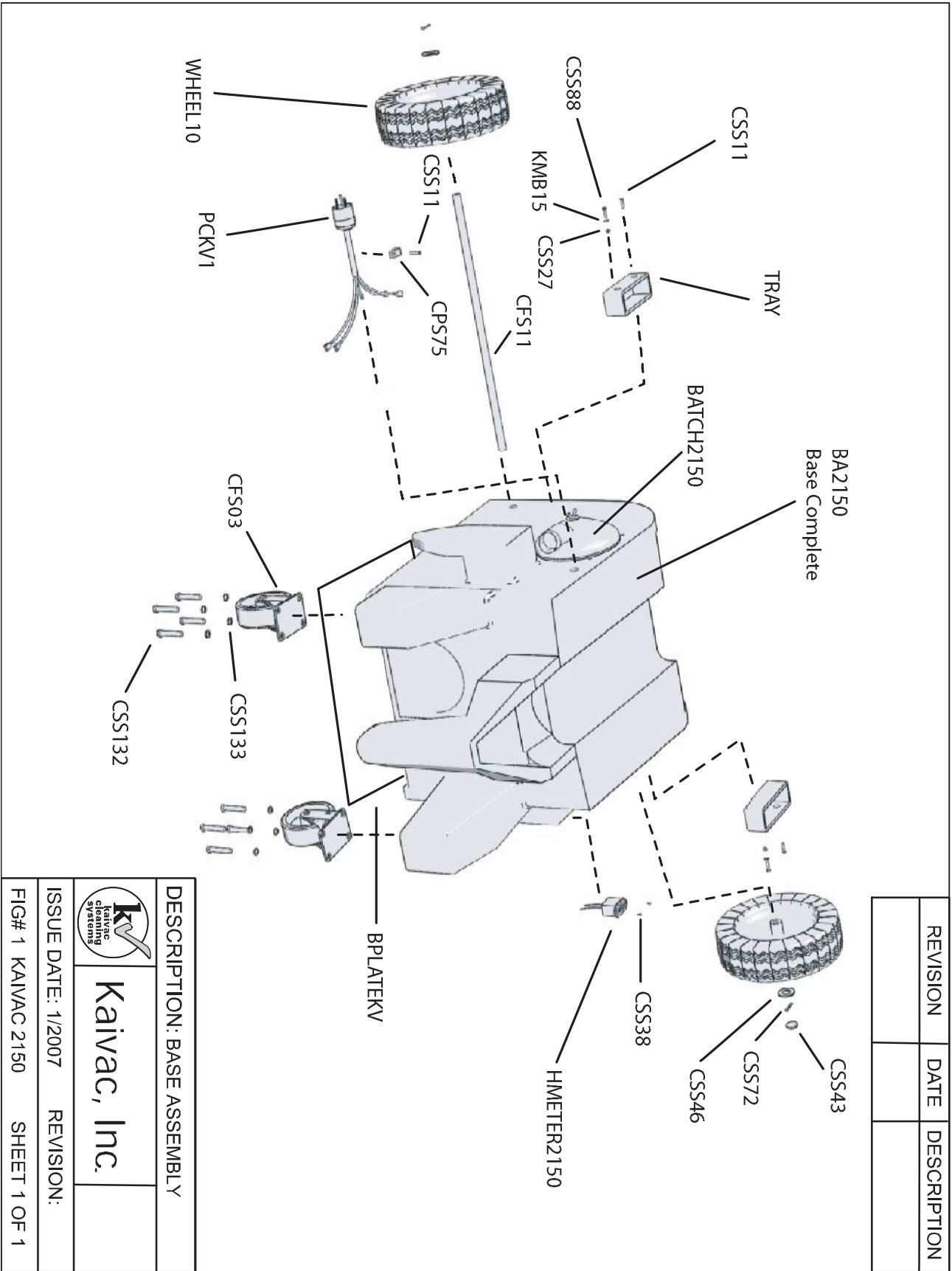

DESCRIPTION: VAC TANK ASSEM.	
	<b>Kaivac, Inc.</b>
ISSUE DATE: 1 /2007	REVISION:
FIG. KAIVAC 2150	SHEET 1 OF 1

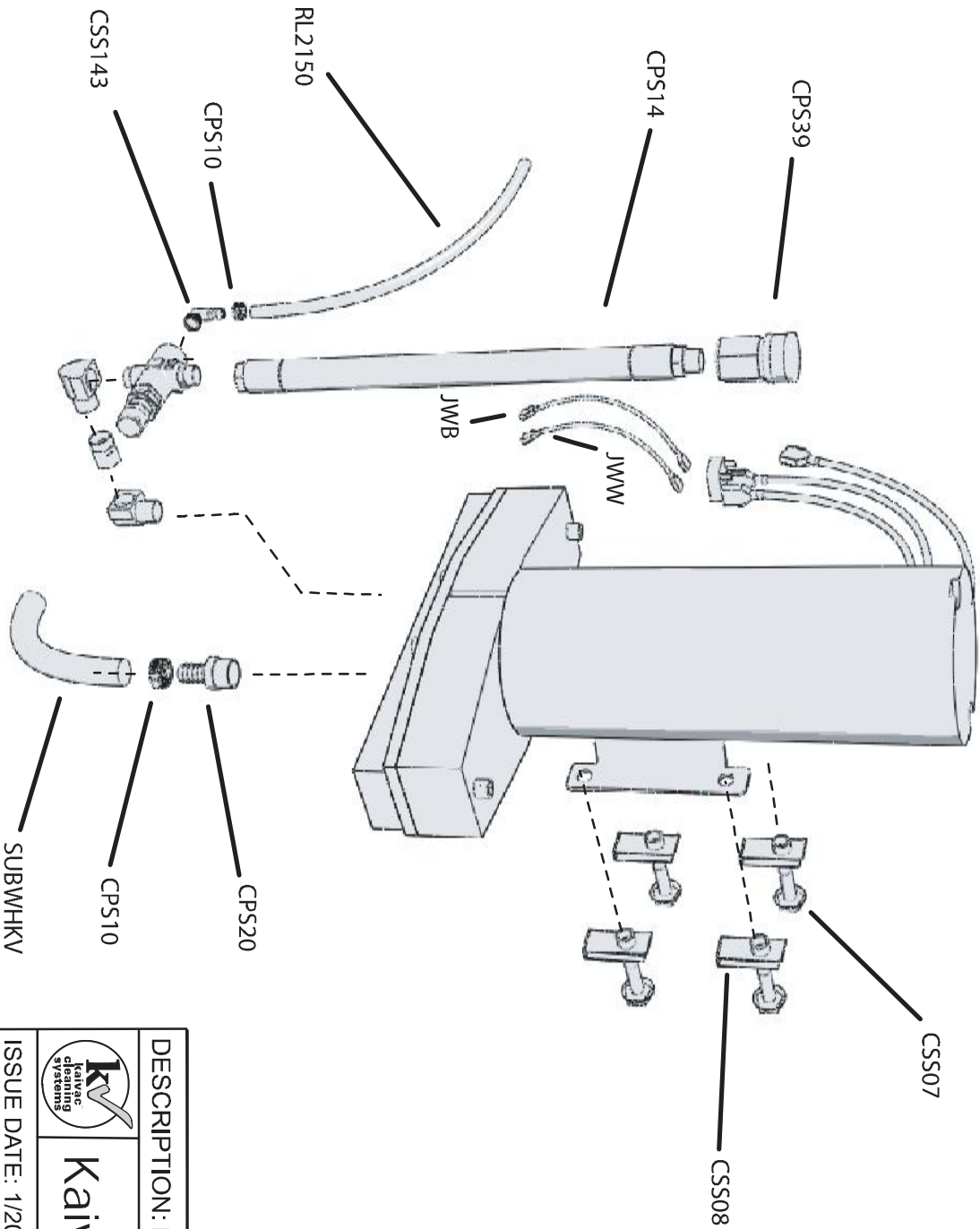

	
<b>Kaivac, Inc.</b>	
DESCRIPTION: BASE ASSEMBLY	
ISSUE DATE: 1/2007	REVISION:
FIG# 1 KAIVAC 2150	SHEET 1 OF 1

REVISION	DATE	DESCRIPTION



	
<b>DESCRIPTION: PUMP MOTOR ASSEM.</b>	
<b>Kaivac, Inc.</b>	
ISSUE DATE: 1/2007	REVISION:
FIG# 1 KAIWAC 2150	SHEET 1 OF 1

REVISION	DATE	DESCRIPTION

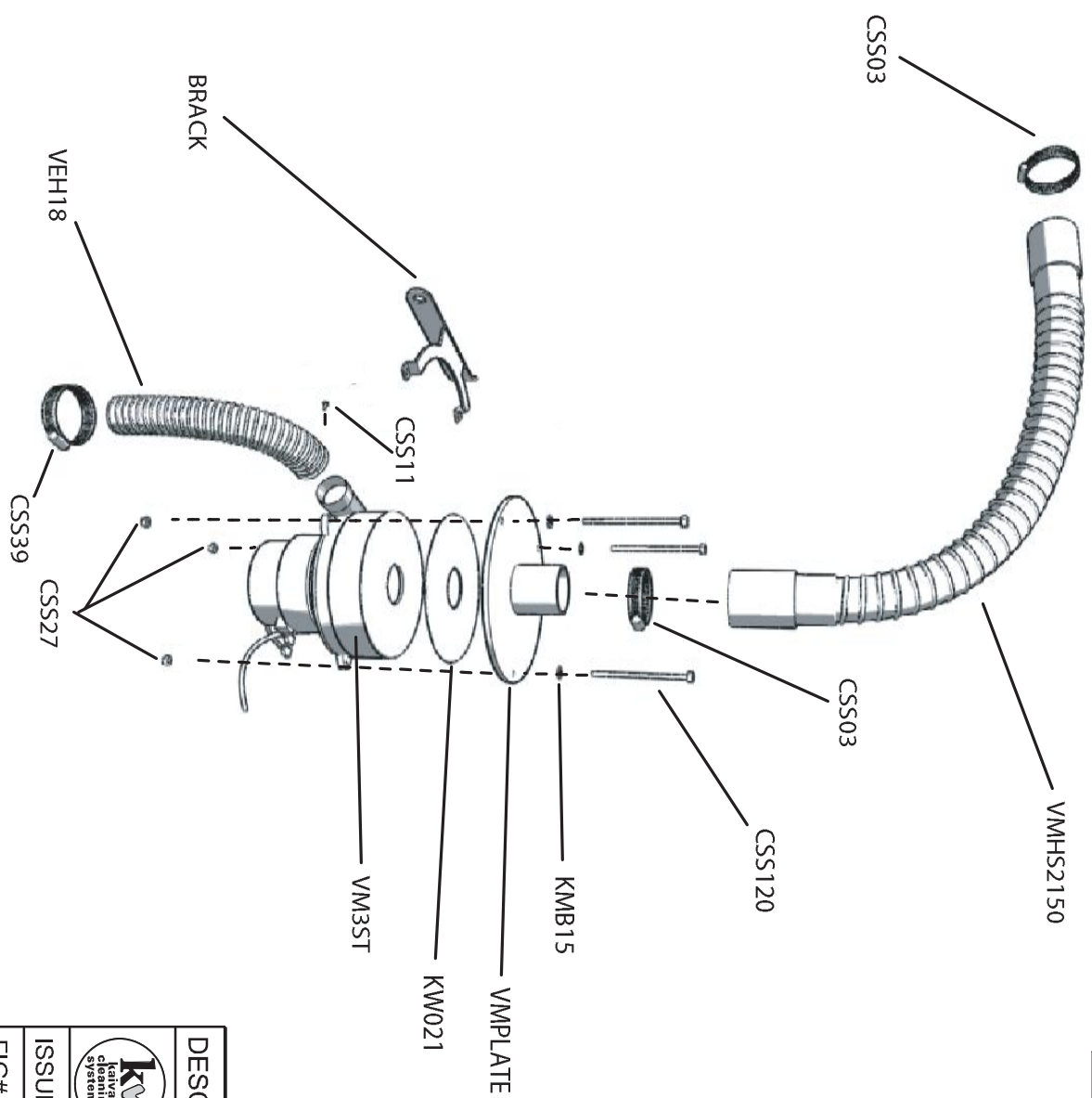

DESCRIPTION: VAC MOTOR	
	<b>Kaivac, Inc.</b>
ISSUE DATE: 1/2007	REVISION:
FIG# 1 KAIWAC2150	SHEET 1 OF 1

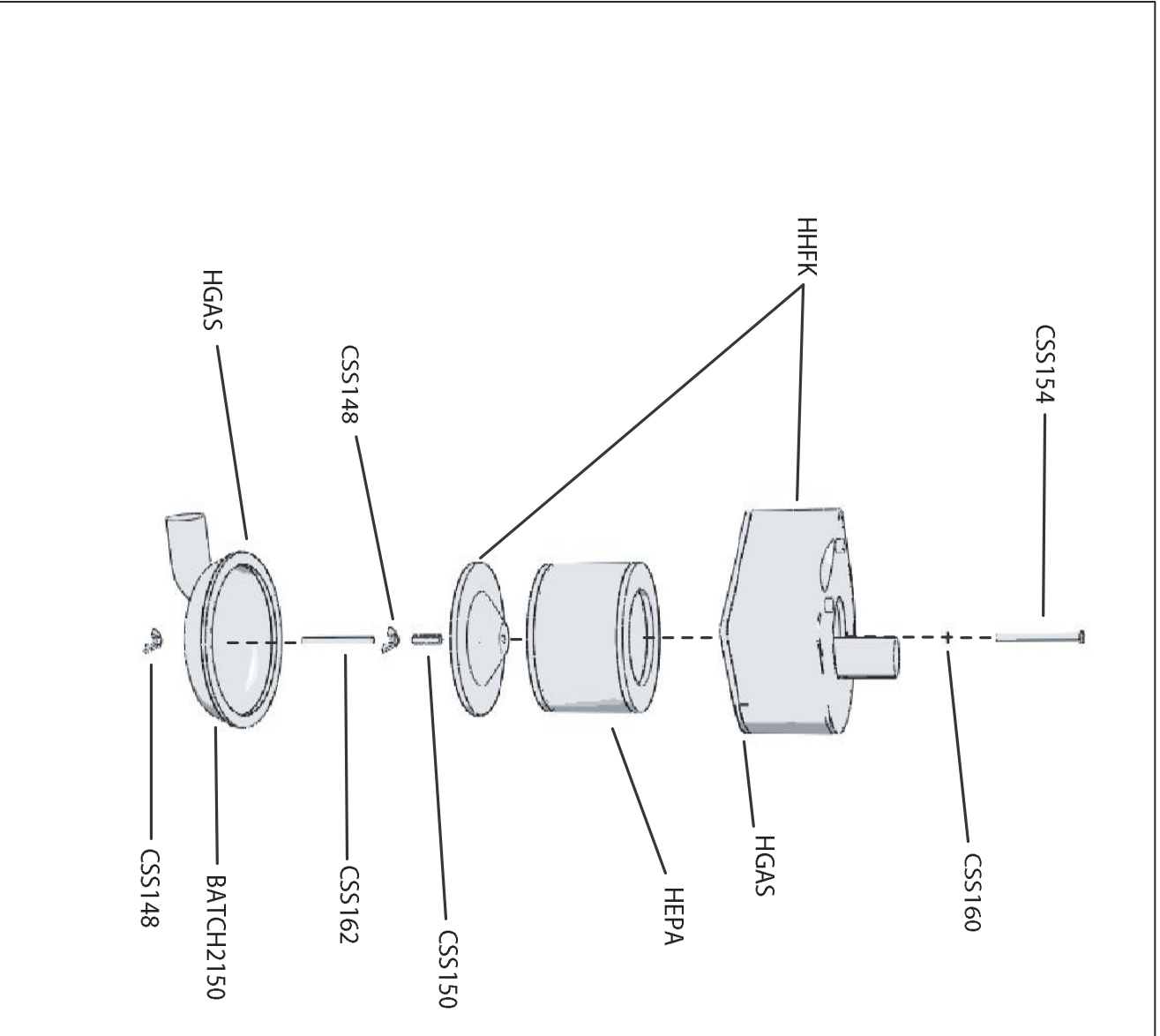

REVISION	DATE	DESCRIPTION

<b>DESCRIPTION: HEPA FILTER ASSEM.</b>		
<b>Kaivac, Inc.</b>		
ISSUE DATE: 1/2007	REVISION:	
FIG# 1 KAIIVAC 2150	SHEET 1 OF 1	







# Parts Listings

PART #	PART DESCRIPTION
	BASE ASSEMBLY
BA2150	BASE COMPLETS
CSS43	5/8 PUSH CAP NUT
CSS72	COTTER PIN
CSS46	5/8 STEEL WASHER
CSS38	RIVET
HMETER2150	HOUR METER
BPLATEKV	BOTTOM PLATE FOR KAIVAC
CSS132	5/16-18 X 1 BUTTON HEAD BOLT
CSS133	5/16 SPLIT WASHER
CFS03	5" CASTER
PCKV1	POWER CORD W/MALE PLUG
CPS75	CABLE CLAMP
CSS11	3/4 SCREW
WHEEL10	10" FLAT FREE TIRE
CFS11	5/8 X 23" AXLE
CSS27	1/4" NYLOC NUT
KMB15	1/4" WASHER
CSS88	1/4-20 X 3/4 SCREW
CSS11	3/4" SCREW
TRAY	TRAY
BATCH2150	BLOW ATTACHMENT COVER
	PUMP MOTOR ASSEMBLY
CSS07	5/16 -18 X 1 HEX HEAD
CSS08	5/16 -18 U-NUT
CPS20	3/8 X 1/2 HOSE BARB
CPS10	7/16 X 25/32 HOSE CLAMP
SUBWHKV	WATER LINE
CSS143	3/8 90DEG. BRASS HOSE BARB
CPS10	7/16 X 25/32 HOSE CALMP
RL2150	RETURN WATER LINE
CPS14	PULSE HOSE
JWB	JUMPER WIRE BLACK
JWW	JUMPER WIRE WHITE
CPS39	3/8 QD COUPLER

# Parts Listings

PART #	PART DESCRIPTION
	VAC MOTOR ASSEMBLY
CSS03	1 9/16 X 2 1/2 CLAMP
VMHS2150	VAC MOTOR HOSE
CSS03	1 9/16 X 2 1/2 CLAMP
CSS120	1/4-20 X 4 BOLT
KMB15	1/4" WASHER
VMPLATE	VAC MOTOR PLATE
KW021	GASKET
VM3ST	VAC MOTOR 3 STAGE
CSS27	1/4" NYLOC NUT
CSS39	1 9/16 X 2" CLAMP
VEH18	VAC EXHAUST HOSE 18"
BRACK	VAC MOUNT BRACKET
CSS11	3/4" SCREW
	HEPA FILTER ASSEMBLY
CSS154	1/4 X 2 1/2 CARRIAGE BOLT
CSS160	O-RING
KKFK	HEPA HOUSING AND FILTER KEEPER
HAGS	GASKET
HEPA	HEPA FILTER
CSS150	1/4" COUPLING NUT
CSS148	WING FLANGE NUT
CSS162	1/4-20 X 2 3/4 THREADED ROD
HGAS	GASKET
BATCH2150	BLOW ATTACHMENT COVER
CSS148	WING FLANGE NUT
	CONTROL PANEL ASSEMBLY
CES08	1/4-20 X 4 SCREW
SPH24	BRAIDED HOSE 1/4" X 2'
CPS65	1/2" CLAMP
CPS01	BRAIDED HOSE 1/4" X 2"
CPS12J	CHEMICAL INJECTOR
CPS64	90DEG 3/8 MALE X 3/8 FEMALE
HERCHOSE	HERCHOSE
CPS50A	3 WAY VALVE
CPS68	90 DEG. 1/8 X 1/4 BRASS BARB
CES02B	ROCKER SWITCH
CPS50B	BLACK CHEMICAL VALVE KNOB
KMB15	1/4" FLAT WASHER



**PAGE DIVIDER**